

September 4<sup>th</sup> 2012 Subject: **Suspension Spring Chart**

No. **2013-4**

YEAR	MODEL	MODEL NUMBER	SERIAL NUMBER
2013	All	All	All

This bulletin is divided into 3 main sections:

**Section 1: Spring Identification**

- Spring identification guideline. Gives information on color codes, part number and spring shape.

**Section 2: Spring Applications**

- Quick reference chart which provides authorized spring application for each Ski-Doo model. It contains the standard spring part number (in gray shading) as installed at the factory, as well as 1 softer spring and 1 harder spring recommendation.

**Section 3: Spring Specifications**

- Refers to spring specifications table.

## SECTION 1: SPRING IDENTIFICATION

### Coil Spring Identification

Spring identification is done by color code stripes **or** by its part number printed on the spring with white ink within the first 1-1/4 coils.

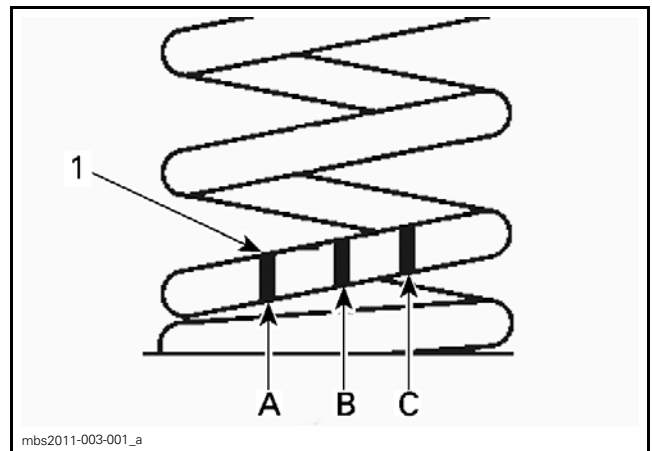

**IDENTIFICATION BY COLOR STRIPES**

1. Color stripes when spring is upright with the stripes down
  - A. 1<sup>st</sup> stripe
  - B. 2<sup>nd</sup> stripe
  - C. 3<sup>rd</sup> stripe

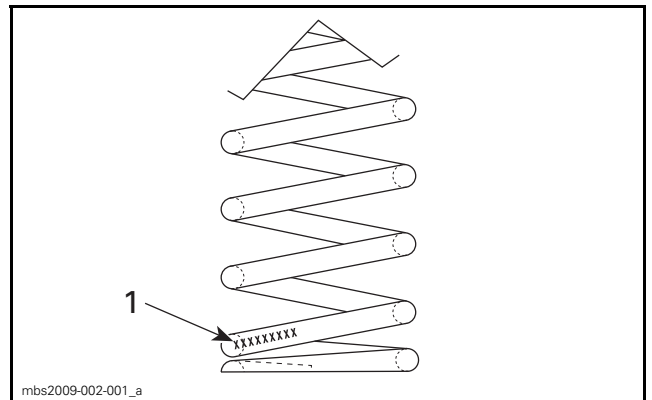

**IDENTIFICATION BY THE SPRING PART NUMBER**

1. Part number

## Color Code Legend

COLOR CODE					
BL	—	BLUE	PI	—	PINK
BK	—	BLACK	RD	—	RED
GD	—	GOLD	SI	—	SILVER
GN	—	GREEN	WH	—	WHITE
OR	—	ORANGE	YL	—	YELLOW

## Coil Spring Types

All call-outs below each following illustrations (except torsion springs) refer to:

1. Color code stripes
2. Wire diameter
3. Free length
4. Positioning tab (where applicable).

Spring type		
Type R (straight at both ends)	Single Rate Spring	
Type S (barrel shape at one end)	Single Rate Spring	
Type T (barrel shape at both ends)	Single Rate Spring	
Type V (barrel shape at both ends)	Single Rate Spring	

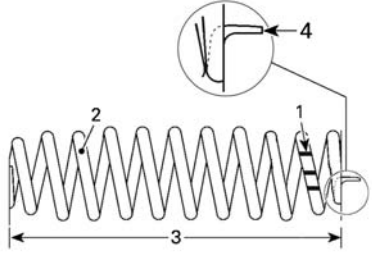
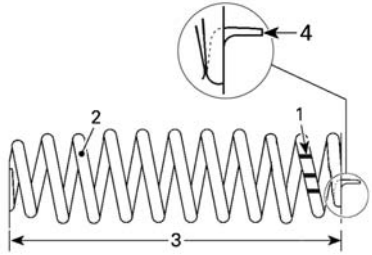
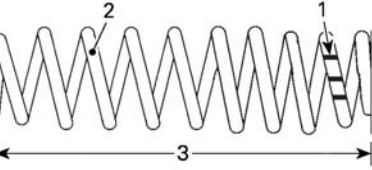
<p>Type Y (barrel shape at both ends with positioning tab at the identification code coils end)</p>	<p>Single Rate Spring</p>	
<p>Type Z (barrel shape at both ends with positioning tab at identification code coils end and 2 different diameter ends)</p>	<p>Single Rate Spring</p>	
<p>Type 2 (barrel shape at both ends)</p>	<p>Dual Rate Spring</p>	

# Torsion Spring Identification

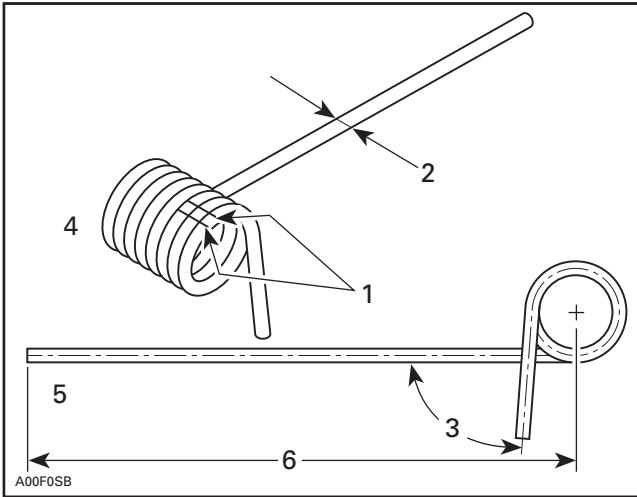

## IDENTIFICATION BY COLOR STRIPES

1. Color code stripes
2. Wire diameter
3. Opening angle (°)
4. Left hand (LH)
5. Right hand (RH)
6. Length

Spring identification is done by color code stripes (as shown above) **or** by its part number printed on the spring with white ink (as shown below).

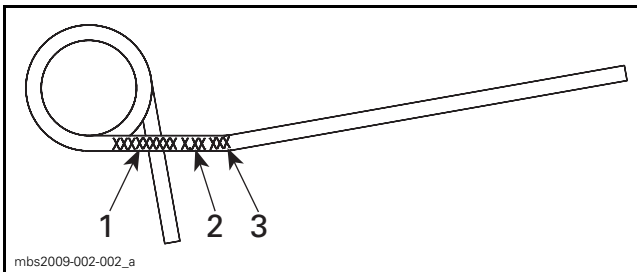

## IDENTIFICATION BY THE SPRING PART NUMBER

1. Spring P/N
2. Spring rate
3. Angle dimension

## Color Code Legend

COLOR CODE					
BL	—	BLUE	PI	—	PINK
BK	—	BLACK	RD	—	RED
GD	—	GOLD	SI	—	SILVER
GN	—	GREEN	WH	—	WHITE
OR	—	ORANGE	YL	—	YELLOW

## SECTION 2: SPRING APPLICATIONS

### FRONT SPRINGS



MODEL	(P/N) SOFTER	(P/N) STANDARD	(P/N) HARDER
Freeride			
Freeride 137/146/154	N.A.	505 072 760	505 073 315
Freeride 154 R (wide stance)	505 072 760	505 073 315	505 072 687
GSX Series			
GSX SE 800R E-TEC (Black) / LE 600 E-TEC	505 072 792	505 072 119	505 072 993
GSX SE 1200 4-TEC / LE 1200	505 072 119	505 072 993	N.A.
Grand Touring Series			
Grand Touring Sport 550F/600	505 072 668	505 072 897	505 072 518
Grand Touring Sport 600 ACE	505 072 668	505 072 897	505 072 518
Grand Touring LE 600HO E-TEC	505 072 414	505 071 842	505 072 518
Grand Touring LE 1200 4-TEC / Grand Touring SE 1200 4-TEC (Full Moon)	505 071 842	505 072 518	N.A.
Grand Touring SE 1200 (Pure Magnesium)	N.A.	505 073 255	N.A.
MX Z Series			
MXZ Sport 550F/600/600 ACE	505 072 763	505 073 265	505 072 116
MXZ Sport 600 ACE EUR/550 EUR	505 072 526	505 072 537	505 072 528
MXZ TNT 600HO E-TEC/800R E-TEC	505 072 526	505 072 537	505 072 528
MX Z TNT 1200 4-TEC	505 072 537	505 072 528	N.A.
MXZ X 1200 4-TEC (black)	505 072 741	505 072 761	N.A.
MXZ X 600HO E-TEC/800R E-TEC	505 072 846	505 072 741	505 072 761
MXZ X-RS 600HO E-TEC/800R E-TEC	N.A.	505 073 262	505 073 272
Renegade Series			
Renegade Sport 550F/600ACE	505 072 667	505 072 791	505 072 515
Renegade Adrenaline 600HO E-TEC/800R E-TEC	505 072 233	505 072 230	505 072 514
Renegade Adrenaline 1200 4-TEC	505 072 230	505 072 514	N.A.
Renegade Backcountry 600HO E-TEC/800R E-TEC	N.A.	505 072 233	505 072 230
Renegade Backcountry X (black)	505 072 726	505 072 846	505 072 741
Renegade X 600HO E-TEC/800R E-TEC (black)	505 072 846	505 072 741	505 072 761
Renegade X 1200 4-TEC (black)	505 072 741	505 072 761	N.A.
Renegade Sport Eur 550/600 ACE	505 072 233	505 072 230	505 072 514

## FRONT SPRINGS



MODEL	(P/N) SOFTER	(P/N) STANDARD	(P/N) HARDER
SUMMIT Series			
Summit Sport 600	505 072 792	505 072 763	505 072 791
Summit Sport 800R Power Tek	505 072 792	505 072 763	505 072 791
Summit SP 600HO E-TEC/800R E-TEC	N.A.	505 072 792	505 072 119
Summit X	N.A.	505 072 726	505 072 741
Expedition Series			
Expedition Sport 550F/600 ACE	505 072 668	505 072 897	505 072 518
Expedition LE 600HO E-TEC / Expedition SE 600HO E-TEC	N.A.	503 192 286	505 072 882
Expedition LE 1200 4-TEC / Expedition SE 1200 4-TEC	503 192 286	505 072 882	505 072 879
Skandic Series			
Tundra LT 550F / Tundra Sport 550F	N.A.	505 072 557	505 072 745
Tundra Sport 600 ACE	505 072 557	505 072 745	505 073 327
Tundra LT 600 ACE / Tundra Xtreme	505 072 557	505 072 745	505 073 327
Skandic WT 550F/600 ACE/600HO E-TEC (REV-XU)	505 072 557	505 072 745	505 073 327
Skandic SWT 600 ACE/600HO E-TEC (REV-XU)	505 072 557	505 072 745	505 073 209
Skandic SWT V-800	M5241330	605 625 001	NA

## CENTER SPRINGS



MODEL	(P/N) SOFTER	(P/N) STANDARD	(P/N) HARDER
Freeride			
Freeride 137	N.A.	503 192 217	503 192 064
Freeride 154	N.A.	503 193 479 503 193 065	503 192 724 503 192 744
Freeride 154 R (wide stance)	N.A.	503 192 724 503 192 744	N.A.
GSX Series			
GSX LE 600HO E-TEC	503 191 476	503 191 329	503 191 879
GSX LE 1200 4-TEC / GSX SE 1200 4-TEC	503 191 879	503 191 882	503 191 880
GSX SE 600HO E-TEC/800R E-TEC	503 191 329	503 191 879	503 191 882
Grand Touring Series			
Grand Touring Sport 550F/600/600 ACE	503 191 879	503 191 882	503 191 880
Grand Touring LE 600HO E-TEC	503 191 476	503 191 329	503 191 879
Grand Touring LE 1200 4-TEC / GTX SE 1200 4-TEC	503 191 329	503 191 879	503 191 882
MX Z Series			
MXZ Sport 550F/600	503 191 476	503 191 329	503 191 879
MXZ Sport 600 ACE	503 191 329	503 191 879	503 191 882
MXZ TNT/ MXZ X 600HO E-TEC/800R E-TEC	N.A.	503 793 480 503 193 067	503 191 343 503 192 279
MXZ TNT 1200 4-TEC/ MXZ 1200	503 193 480 503 193 067	503 193 068 503 193 160	503 191 343 503 192 279
MXZ X-RS 600HO E-TEC/800R E-TEC	N.A.	503 193 479 503 193 065	503 192 724 503 192 744
Renegade Series			
Renegade Sport 550F/600 ACE	503 191 879	503 191 882	503 191 880
Renegade Adrenaline/Backcountry/Backcountry X 600HO E-TEC/800R E-TEC	N.A.	503 193 480 503 193 067	503 191 343 503 192 279
Renegade Adrenaline 1200 4-TEC / Renegade X 1200 4-TEC	503 191 882	503 193 068 503 193 160	503 191 343 503 192 279
SUMMIT Series			
Summit Sport & SP	503 191 879	503 191 882	503 191 880
Summit X	N.A.	503 193 249	N.A.
Expedition Series			
Expedition Sport 550F	503 191 879	503 191 882	503 191 880
Expedition Sport 600 ACE	503 191 882	503 191 880	503 189 686

## CENTER SPRINGS



MODEL	(P/N) SOFTER	(P/N) STANDARD	(P/N) HARDER
Expedition Series (cont'd)			
Expedition LE 600HO E-TEC / Expedition SE 600HO E-TEC	503 191 882	503 191 880	503 189 686
Expedition LE 1200 4-TEC / Expedition SE 1200 4-TEC	503 191 880	503 189 686	N.A.
Skandic Series			
Tundra / Tundra LT 550F/ Tundra Sport 550F	503 191 879	503 191 882	503 191 880
Tundra Sport 600 ACE	503 191 882	503 191 880	503 189 686
Tundra LT 600 ACE	503 191 882	503 191 880	503 189 686
Tundra Xtreme	503 190 476 503 190 478	503 191 343 503 192 279	503 190 982 503 190 854
Skandic WT 550F/600ACE/600HO E-TEC (REV-XU)	503 191 882	503 191 880	503 189 686
Skandic SWT 600 ACE/600HO E-TEC (REV-XU)	503 191 882	503 191 880	503 189 686
Skandic SWT V-800	N.A.	605 354 840 (right) 605 354 839 (left)	M5241178 (right) M5241177 (left)



## REAR SPRINGS



MODEL	(P/N) SOFTER	(P/N) STANDARD	(P/N) HARDER
<b>Freeride</b>			
Freeride 137	503 191 612 (right) 503 191 613 (left)	503 191 186 (right) 503 191 188 (left)	503 191 614 (right) 503 191 615 (left)
Freeride 146/154	503 192 080 (right) 503 192 081 (left)	503 192 137 (right) 503 192 136 (left)	503 192 270 (right) 503 192 271 (left)
Freeride 154 R (wide stance)	503 190 712 (right) 503 190 714 (left)	503 192 080 (right) 503 192 081 (left)	503 191 287 (right) 503 191 289 (left)
<b>GSX Series</b>			
GSX LE 600HO E-TEC	N.A.	503 191 612 (right) 503 191 613 (left)	503 191 614 (right) 503 191 615 (left)
GSX LE 1200 4-TEC	503 191 612 (right) 503 191 613 (left)	503 191 186 (right) 503 191 188 (left)	503 191 614 (right) 503 191 615 (left)
GSX SE 600HO E-TEC/800R E-TEC/1200 4-TEC	N.A.	503 192 267 (right) 503 192 268 (left)	503 191 612 (right) 503 191 613 (left)
<b>Grand Touring Series</b>			
Grand Touring Sport 550F/600/600 ACE	503 191 287 (right) 503 191 289 (left)	503 192 270 (right) 503 192 271 (left)	503 191 247 (right) 503 191 249 (left)
Grand Touring LE	503 191 614 (right) 503 191 615 (left)	503 191 616 (right) 503 191 617 (left)	503 191 892 (right) 503 191 893 (left)
Grand Touring SE	503 191 186 (right) 503 191 188 (left)	503 192 061 (right) 503 192 062 (left)	503 191 892 (right) 503 191 893 (left)
<b>MX Z Series</b>			
MXZ Sport	N.A.	503 191 612 (right) 503 191 613 (left)	503 191 614 (right) 503 191 615 (left)
MXZ XRS EUR	503 193 158 503 193 159	503 192 270 503 192 271	503 191 247 503 191 249
MXZ X 600HO E-TEC/800R E-TEC / X TNT E-TEC	503 192 080 (right) 503 192 081 (left)	503 193 158 (right) 503 193 159 (left)	503 192 270 (right) 503 192 271 (left)
MXZ X 1200 4-TEC / X TNT 1200	503 192 080 (right) 503 192 081 (left)	503 193 158 (right) 503 193 159 (left)	503 192 270 (right) 503 192 271 (left)
MXZ X-RS 600HO E-TEC/800R E-TEC	503 192 080 (right) 503 192 081 (left)	503 193 158 (right) 503 193 159 (left)	503 192 270 (right) 503 192 271 (left)
<b>Renegade Series</b>			
Renegade Sport 550F/600 ACE	N.A.	503 192 080 (right) 503 192 081 (left)	503 192 270 (right) 503 192 271 (left)
All Renegade Adrenaline / Backcountry / Backcountry X E-TEC/ 1200	503 192 080 503 192 081	503 193 158 (right) 503 193 159(left)	503 192 270 (right) 503 192 271 (left)

## REAR SPRINGS



MODEL	(P/N) SOFTER	(P/N) STANDARD	(P/N) HARDER
SUMMIT Series			
All Summit	503 190 712 (right) 503 190 714 (left)	503 193 002 (right) 503 193 003 (left)	503 191 287 (right) 503 191 289 (left)
Expedition Series			
Expedition Sport 550F/600 ACE	503 191 287 (right) 503 191 289 (left)	503 192 270 (right) 503 192 271 (left)	503 191 247 (right) 503 191 249 (left)
Expedition LE 600HO E-TEC / Expedition SE 600HO E-TEC	N.A.	503 192 377 (right) 503 192 378 (left)	N.A.
Expedition LE 1200 4-TEC / Expedition SE 1200 4-TEC	N.A.	503 192 377 (right) 503 192 378 (left)	N.A.
Skandic Series			
Tundra / Tundra Sport 550F/600 ACE	N.A.	503 192 080 (right) 503 192 081 (left)	503 192 270 (right) 503 192 271 (left)
Tundra LT /Tundra Xtreme	503 192 080 (right) 503 192 081 (left)	503 192 136 (right) 503 192 137 (left)	503 192 270 (right) 503 192 271 (left)
Skandic WT 550F/600 ACE/600HO E-TEC (REV-XU)	N.A.	503 192 377 (right) 503 192 378 (left)	503 192 910 (right) 503 192 911 (left)
Skandic SWT 600 ACE/600HO E-TEC (REV-XU)	503 192 377 (right) 503 192 378 (left)	503 192 910 (right) 503 192 911 (left)	N.A.
Skandic SWT V-800	N.A.	M538806 (right) M538805 (left)	M5342228 (right) M5342229 (left)

# SECTION 3: SPRING SPECIFICATIONS

## Coil Springs Specifications

P/N	TYPE	SPRING RATE (LB/IN) ±10	FREE LENGTH (MM) ±3	WIRE DIAMETER (MM) ±.05	COLOR CODE	COLOR OF SPRING
503 189 999	R	325	189	9.52	GD/SI/YL	BLACK
503 190 471	R	215	64	6.35	WH/WH/YL	BLACK
503 190 476	R	210	64.6	6.65	BL/SI/YL	BLACK
503 190 478	S	240	178	9.19	GN/SI/YL	BLACK
503 190 546	2	125	250	8.25	RD/WH/RD	BLACK
503 190 854	R	325	189	8.84	SI/WH/YL	BLACK
503 190 982	R	319	72	7.14	GD/YL/RD	BLACK
503 191 135	T	135	242	7.92	SI/YL/RD	BLACK
503 191 327	T	275	184	8.25	GD/BL/WH	BLACK
503 191 329	T	110	242	6.95	GD/RD/RD	BLACK
503 191 343	R	223	56	5.94	SI/RD/RD	BLACK
503 191 347	Y	125	264	8.25	SI/BL/RD	BLACK
503 191 356	T	105	242	6.65	SI/WH/BL	BLACK
503 191 476	T	90	242	6.65	GD/RD/GN	BLACK
503 191 488	T	135	201	7.14	GD/WH/GN	BLACK
503 191 879	T	135	242	7.49	detail "A" WH/WH/OR	BLACK
503 191 880	T	180	242	8.25	detail "A"	BLACK
503 191 882	T	150	242	7.77	detail "A"	BLACK
503 192 064	V	175	210	8.25	detail "A"	BLACK
503 192 217	V	135	205	7.49	detail "A"	BLACK
503 192 279	T	275	184	8.71	detail "A"	BLACK
503 192 724	S	275	155	9.19	detail "A"	BLACK
503 192 744	R	222	59	6.17	detail "A"	BLACK
503 193 065	S	190	162	8.25	detail "A"	BLACK
503 193 066	R	197	52	5.94	detail "A"	BLACK
503 193 067	S	190	189	7.92	detail "A"	BLACK
503 193 068	R	175	51	5.54	detail "A"	BLACK
503 193 160	V	275	189	9.19	detail "A"	BLACK
505 071 461	T	75	280	7.49	GN/SI/BK	YELLOW
505 071 492	T	105	280	7.77	WH/RD/GN	YELLOW
505 071 642	Y	75	280	7.49	GN/GN/GN	YELLOW
505 071 647	Y	105	280	7.77	WH/RD/RD	YELLOW
505 071 830	T	125	280	7.77	RD/SI/RD	YELLOW
505 071 833	T	90	280	7.77	WH/WH/BL	YELLOW
505 071 838	T	105	280	7.77	WH/SI/BK	RED
505 071 840	T	105	280	7.77	SI/GD/BK	VIPER RED
505 071 842	T	90	280	7.77	WH/GD/RD	FULL MOON
505 071 844	T	75	280	7.49	WH/WH/GN	SATURN ORANGE
505 071 845	T	75	280	7.49	GD/GD/RD	FULL MOON

P/N	TYPE	SPRING RATE (LB/IN) ±10	FREE LENGTH (MM) ±3	WIRE DIAMETER (MM) ±.05	COLOR CODE	COLOR OF SPRING
505 071 849	T	105	280	7.77	GD/WH/RD	FULL MOON
505 072 022	T	75	280	7.14	SI/GN/BL	RED
505 072 023	Y	75	280	7.14	SI/BL/GN	RED
505 072 024	T	75	280	7.14	WH/YL/GN	FULL MOON
505 072 219	T	90	280	7.77	GD/BL/GN	RED
505 072 230	Y	90	280	7.47	WH/SI/GD	YELLOW
505 072 233	Y	80	280	7.14	SI/SI/GN	YELLOW
505 072 319	T	80	280	7.14	SI/BD/GN	YELLOW
505 072 413	T	80	280	7.14	GD/WH/GD	BLACK
505 072 414	T	80	280	7.14	WH/BK/GD	FULL MOON
505 072 430	Y	75	280	7.14	SI/GN/WH	YELLOW
505 072 431	T	75	208	7.14	SI/SI/WH	YELLOW
505 072 514	Y	120	280	8.25	detail "A"	YELLOW
505 072 515	T	120	280	8.25	detail "A"	YELLOW
505 072 518	T	120	280	8.25	detail "A"	FULL MOON
505 072 526	Y	80	280	7.14	detail "A"	BLACK
505 072 528	Y	120	280	8.25	detail "A"	BLACK
505 072 530	Y	75	280	7.14	detail "A"	ROYAL BLUE
505 072 532	Y	75	280	7.14	detail "A"	BLACK
505 072 537	Y	90	280	7.49	detail "A"	BLACK
505 072 557	T	70	263	5.94	detail "A"	BLACK
505 072 667	T	80	300	7.49	-	YELLOW
505 072 668	T	80	300	7.49	-	FULL MOON
505 072 726	Z	75	280	7.14	detail "A"	BLACK
505 072 735	Y	120	280	8.25	detail "A"	VIPER RED
505 072 739	Y	90	280	7.49	detail "A"	VIPER RED
505 072 741	Z	90	280	7.49	detail "A"	BLACK
505 072 745	T	60	263	6.17	detail "A"	BLACK
505 072 760	V	90	280	7.49	detail "A"	BLACK
505 072 761	Z	120	280	8.25	detail "A"	BLACK
505 072 763	T	80	300	7.49	detail "A"	BLACK
505 072 791	T	90	300	7.92	detail "A"	YELLOW
505 072 792	T	75	280	7.14	detail "A"	BLACK
505 072 800	Z	95	280	7.49	detail "A"	BLACK
505 072 846	Z	80	280	7.14	detail "A"	BLACK
505 072 897	T	90	300	7.92	detail "A"	FULL MOON
505 072 916	T	90	300	7.92	detail "A"	VIPER RED
505 072 953	Z	90	280	7.49	detail "A"	YELLOW
505 072 956	Z	120	280	8.25	detail "A"	YELLOW
505 072 936	Y	80	280	7.14	detail "A"	VIPER RED
505 072 968	V	90	280	7.42	detail "A"	CASINO GOLD
505 072 990	Z	120	280	8.25	detail "A"	VIPER RED
505 072 993	T	120	280	8.25	detail "A"	BLACK

P/N	TYPE	SPRING RATE (LB/IN) ±10	FREE LENGTH (MM) ±3	WIRE DIAMETER (MM) ±.05	COLOR CODE	COLOR OF SPRING
505 073 067	Z	80	280	7.14	detail "A"	VIPER RED
505 073 071	V	75	280	7.14	detail "A"	CASINO GOLD
505 073 073	T	90	280	7.49	detail "A"	YELLOW
505 073 088	Z	90	280	7.49	detail "A"	VIPER RED
505 073 144	V	165	300	9.52	detail "A"	CASINO GOLD
505 073 204	T	88	266	6.65	detail "A"	BLACK
505 073 255	T	120	280	8.25	detail "A"	PURE MAGNESIUM
505 073 262	V	90	280	7.49	detail "A"	PODIUM BRONZE
505 073 265	T	90	280	7.92	detail "A"	BLACK
505 073 272	V	165	280	9.52	detail "A"	PODIUM BRONZE
505 073 315	V	105	280	7.92	detail "A"	BLACK

# Torsion Springs Specifications

## Torsion Springs for SC-5M and rMotion Suspensions

P/N	WIRE DIAMETER (MM)	OPENING ANGLE $\pm 7^\circ$	COLOR CODE	COLOR OF SPRING	CONSTANT (N•MM / DEGREE)
503 190 712 (RIGHT) 503 190 714 (LEFT)	8.85 (SQUARE)	75°	BL/BL	BLACK	1.13
503 191 251 (Right) 503 191 253 (Left)	9.86 (square)	100°	WH/WH	BLACK	1.84
503 191 287 (Right) 503 191 289 (Left)	9.525 (square)	80°	GN/YL/YL	BLACK	1.44
503 191 358 (Right) 503 191 357 (Left)	9.0 (square)	80°	YL/RD/YL	BLACK	1.35
503 191 477 (Right) 503 191 479 (Left)	9.86 (square)	80°	WH/RD	BLACK	1.66
503 191 481 (Right) 503 191 483 (Left)	11.0 x 9.25 (rectangular)	100°	WH/BL	BLACK	2.30
503 192 080 (Right) 503 192 081 (Left)	8.85 (square)	80°	detail "B"	BLACK	1.27
503 192 104 (Right) 503 192 105 (Left)	9.525 (square)	90°	detail "B"	BLACK	1.50
503 192 137 (Right) 503 192 136 (Left)	9.0 (square)	80°	detail "B"	BLACK	1.35
503 192 270 (Right) 503 192 271 (Left)	9.86 (square)	80°	detail "B"	BLACK	1.66
503 193 002 (Right) 503 192 003 (Left)	8.46 (square)	80°	detail "B"	BLACK	1.27
503 193 158 (Right) 503 192 159 (Left)	9.14 (square)	80°	detail "B"	BLACK	1.35

## Torsion Springs for SC-5 Suspension

P/N	WIRE DIAMETER (MM)	OPENING ANGLE $\pm 7^\circ$	COLOR CODE	COLOR OF SPRING	CONSTANT (N•MM / DEGREE)
503 191 186 (Right) 503 191 188 (Left)	8.85 (square)	100°	YL/YL/YL	BLACK	1.33
503 191 612 (Right) 503 191 613 (Left)	8.85 (square)	95°	GN/RD/YL	BLACK	1.28
503 191 614 (Right) 503 191 615 (Left)	9.53 (square)	100°	GN/BL/YL	BLACK	1.56
503 191 616 (Right) 503 191 617 (Left)	9.85 (square)	100°	GN/GN/YL	BLACK	1.73
503 191 892 (Right) 503 191 893 (Left)	11 x 9.25 (rectangular)	100°	GN/OR/YL	BLACK	2.02
503 192 061 (Right) 503 192 062 (Left)	9.70 (square)	90°	detail "B"	BLACK	1.53
503 192 268 (Right) 503 192 267 (Left)	8.58 (square)	100°	detail "B"	BLACK	1.01

---

## Torsion Springs for SC-5U Suspension

P/N	WIRE DIAMETER (MM)	OPENING ANGLE $\pm 7^\circ$	COLOR CODE	COLOR OF SPRING	CONSTANT (N•MM / DEGREE)
503 192 377 (Right) 503 192 378 (Left)	11 x 9.25 (rectangular)	75°	detail "B"	BLACK	1.92
503 192 910 (Right) 503 192 911 (Left)	11 x 11 (square)	75°	detail "B"	BLACK	2.45